

REFERENCE PLAN
FORE, MAIN AND MIZZEN MAST TRUCKS AND LIGHTNING RODS. No 29624

NOTE:
 THIS PLAN OF TOPGALLANT MASTS HAS BEEN DRAWN
 LARGELY FROM OLD TOPGALLANT MASTS INSTALLED DURING
 YEARS 1906-1907.
 CHANGES - SIZES OF SWALLOWS AND SHEAVES FOR STRIKING
 DOWN TOPGALLANT MASTS, SHEAVES REDUCED IN THICKNESS.
 MAIN AND MIZZEN TOPGALLANT MASTS HAVE BEEN MADE
 SLIGHTLY LONGER THAN THOSE INSTALLED DURING YEAR 1906 - SEE PLAN
 No. 14924. ALL FITTINGS REMOVED FROM OLD TOPGALLANT MASTS
 TO BE USED IF FOUND SERVICABLE.

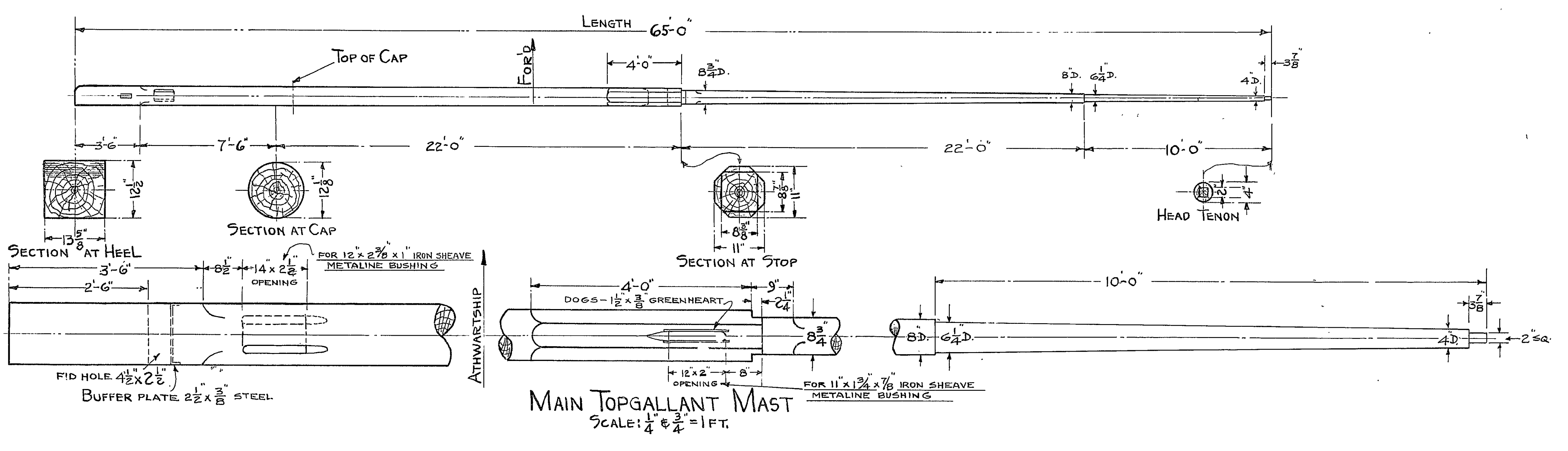

MAIN TOPGALLANT MAST
SCALE: 1/4" = 1 FT.

RESTORATION 1927-1931

U.S. FRIGATE CONSTITUTION

FORE, MAIN AND MIZZEN TOPGALLANT MASTS

NAVY YARD BOSTON. JULY 1929
SCALE: 1/4" = 1 FT.

C. S. Adams
APPROVED FOR MANAGER

IN CHARGE OF WORK: JOHN A. LORD, LIEUT. (C.G.) U.S.N.
DRAWN BY: *J. Munkha*
TRACED BY: *J. Munkha*
CHECKED BY: C. S. ADAMS