

FORE ROYAL YARD

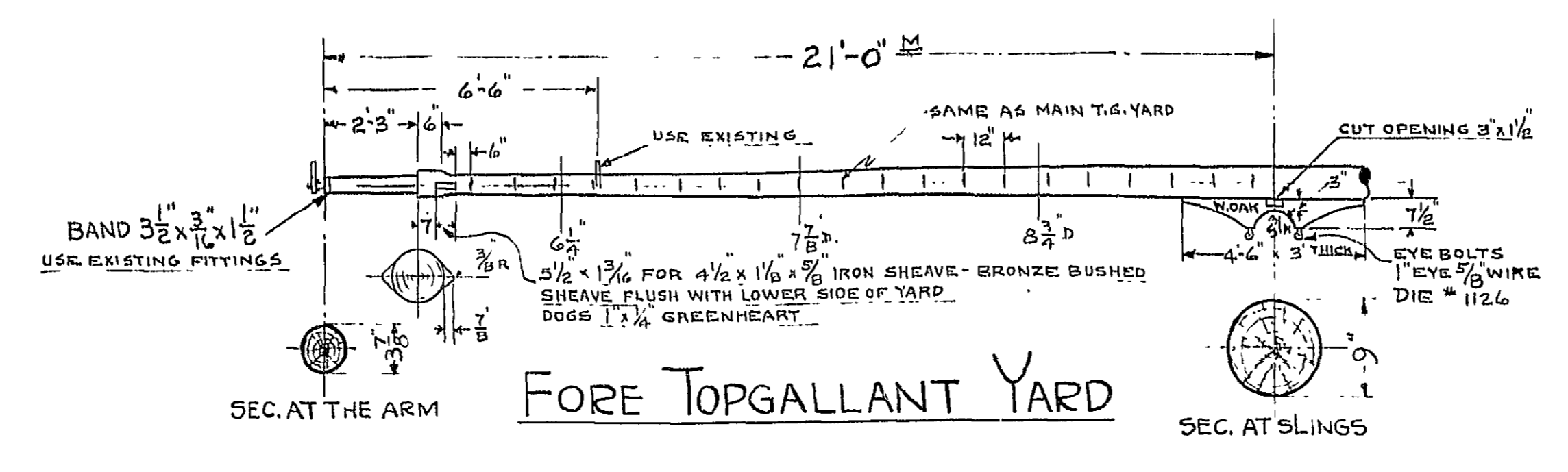

FORE TOPGALLANT YARD

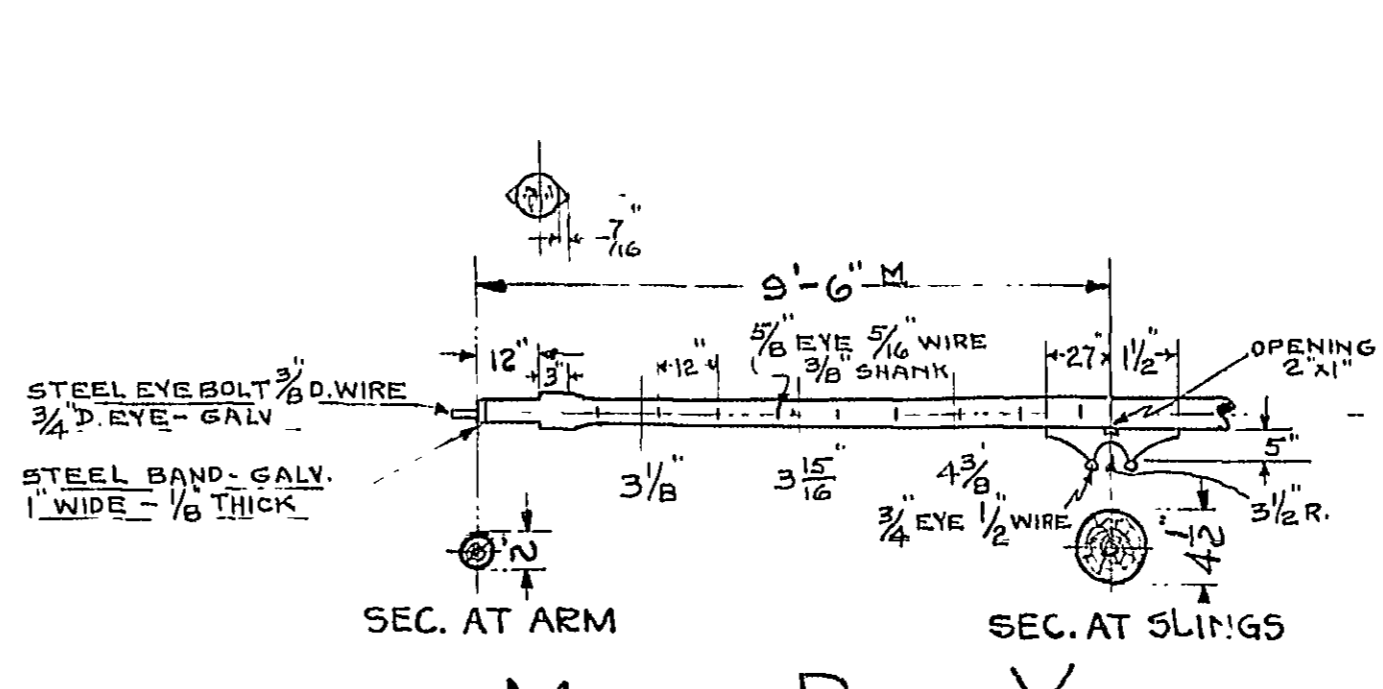

MIZZEN ROYAL YARD

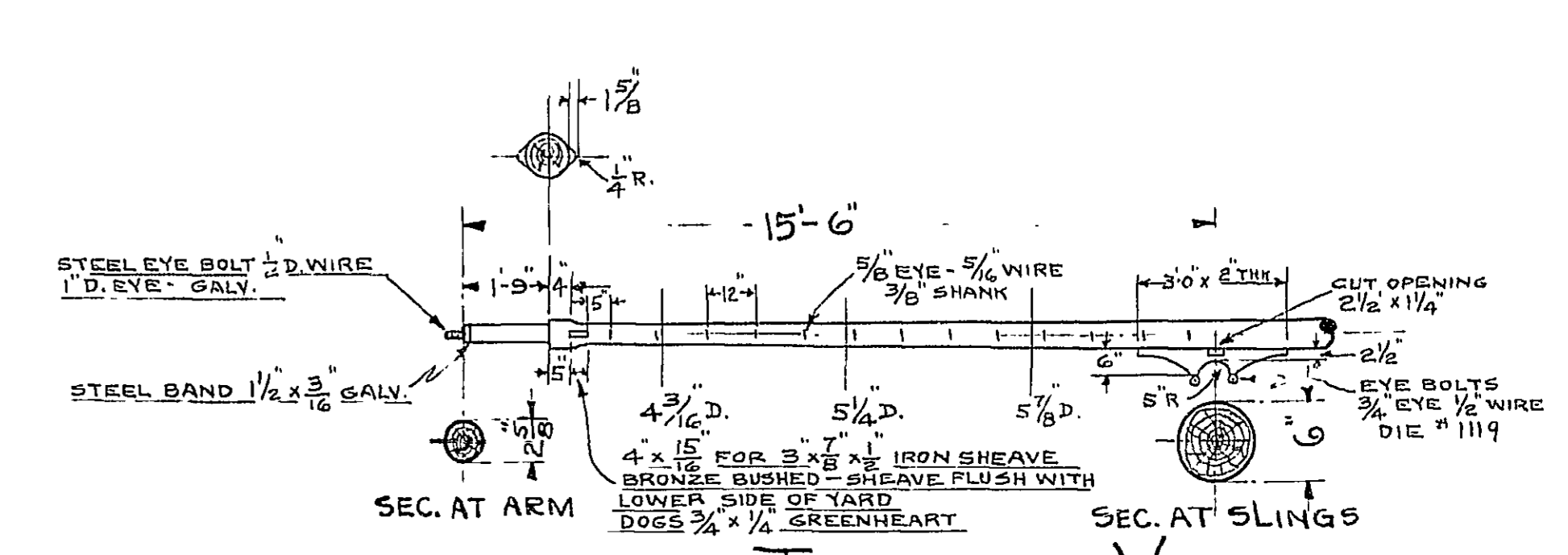

MIZZEN TOPGALLANT YARD

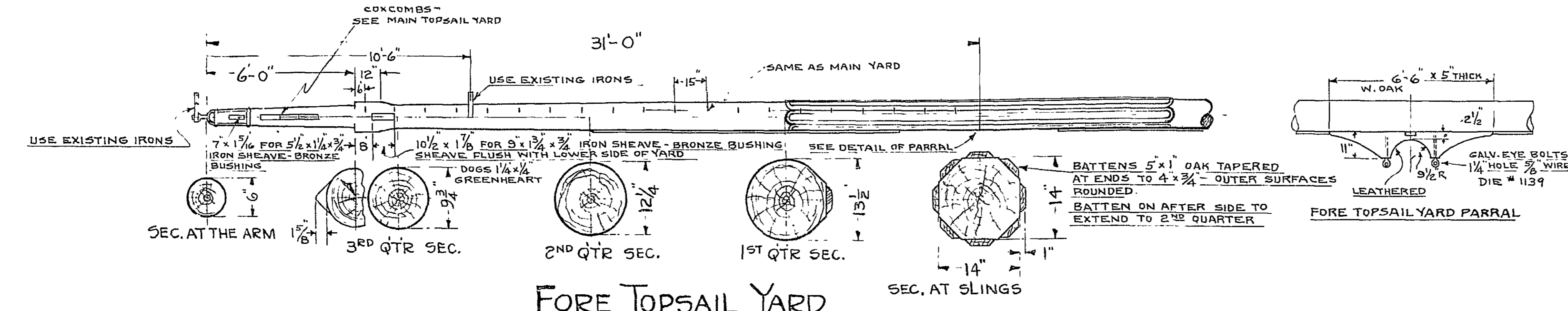

FORE TOPSAIL YARD

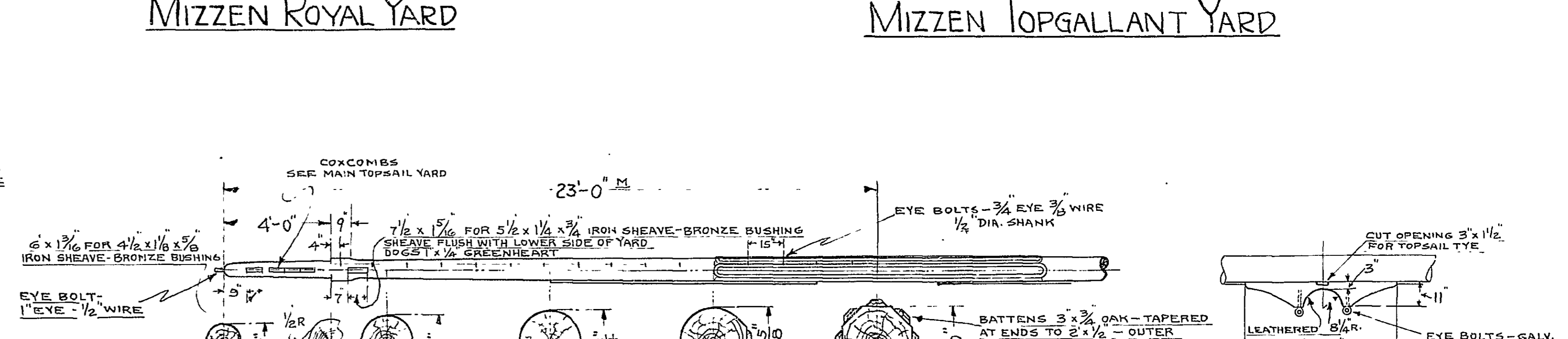

MIZZEN TOPSAIL YARD

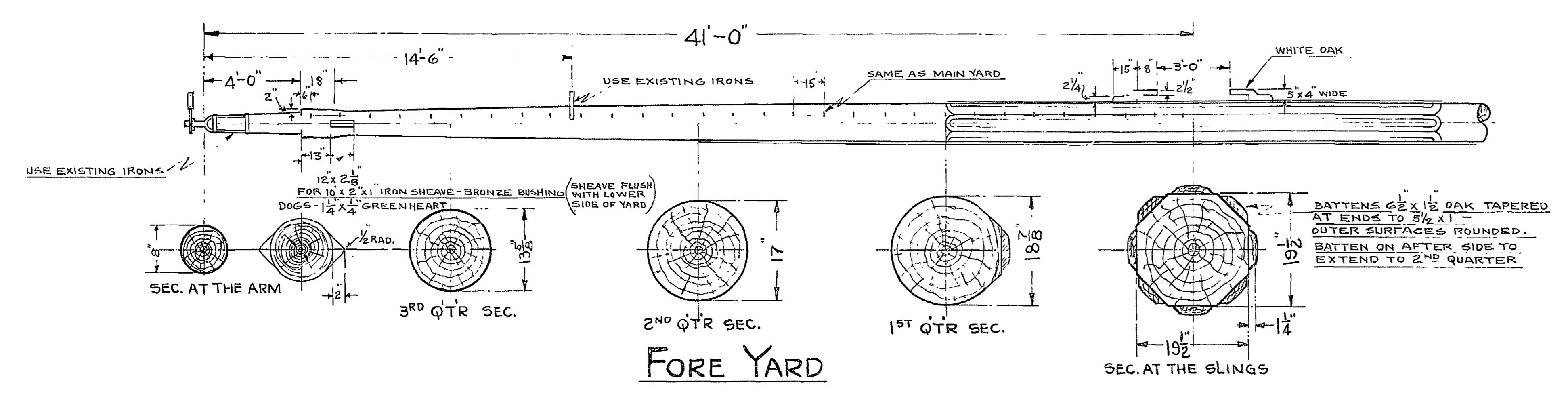

FORE YARD

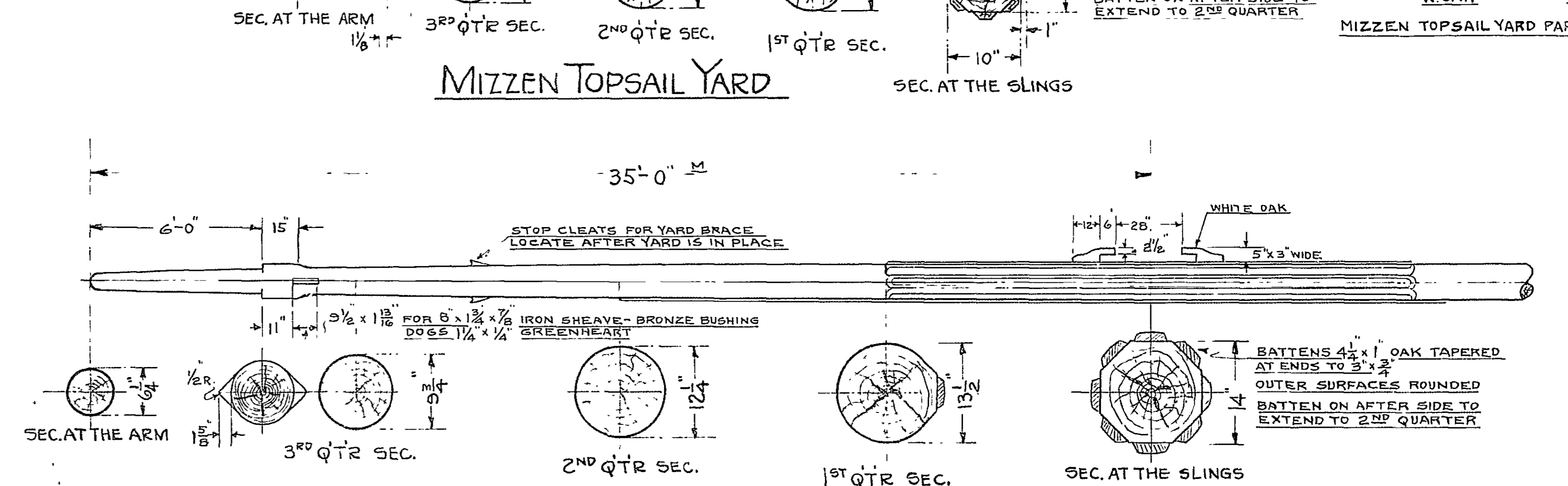

CROSS JACK YARD

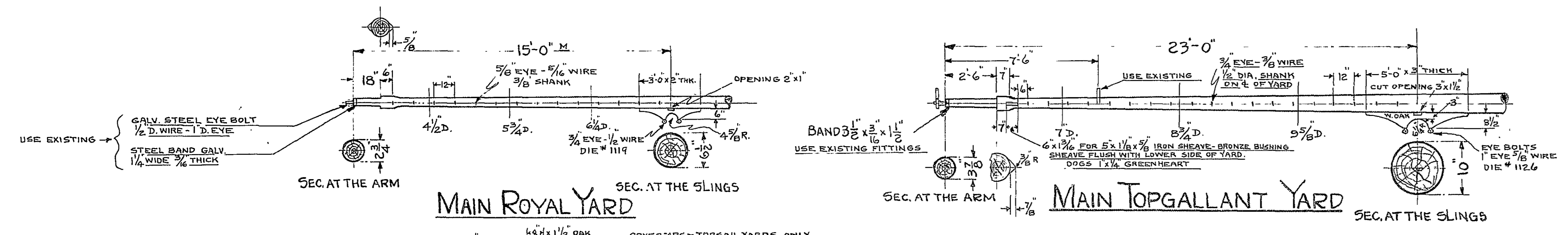

MAIN ROYAL YARD

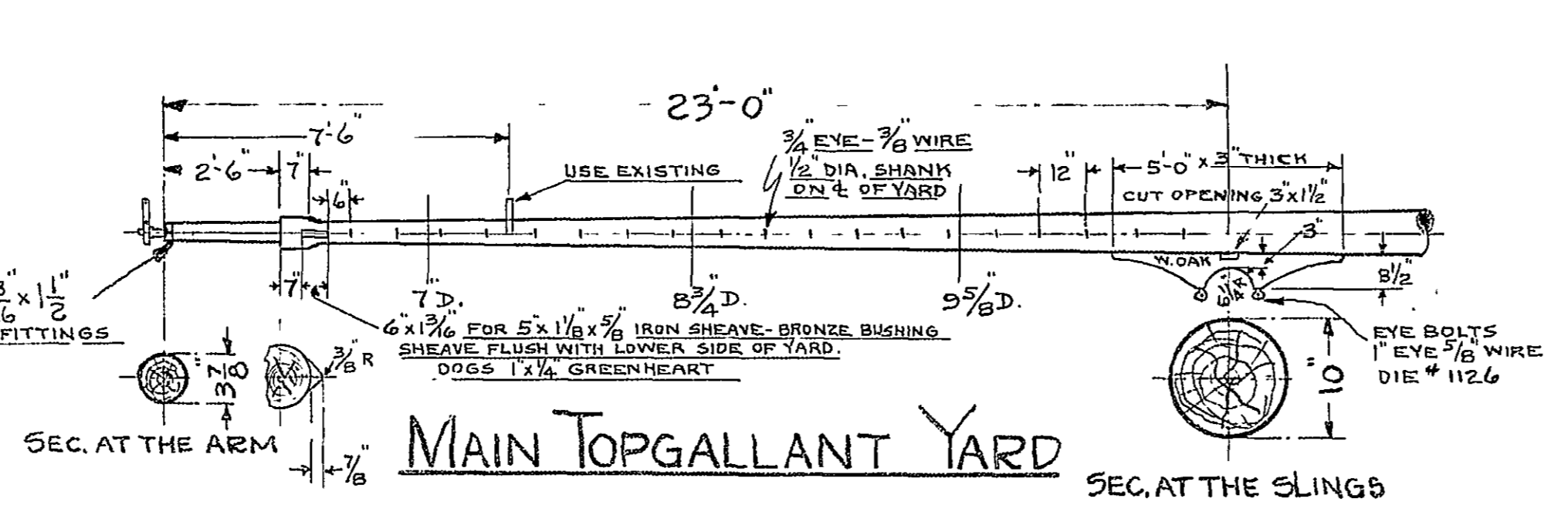

MAIN TOPGALLANT YARD

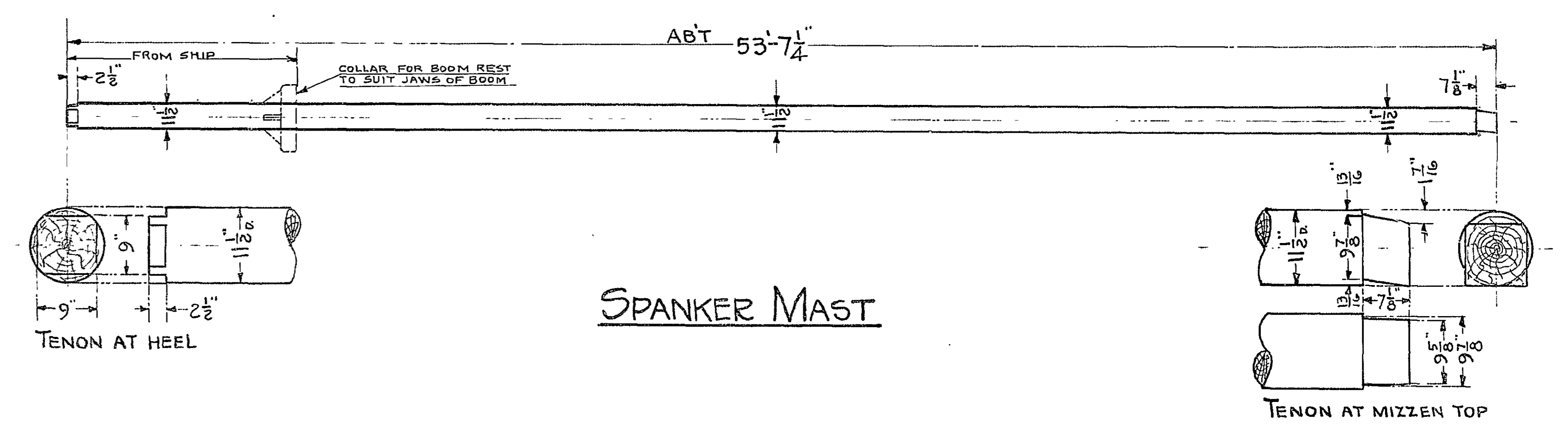

SPANKER MAST

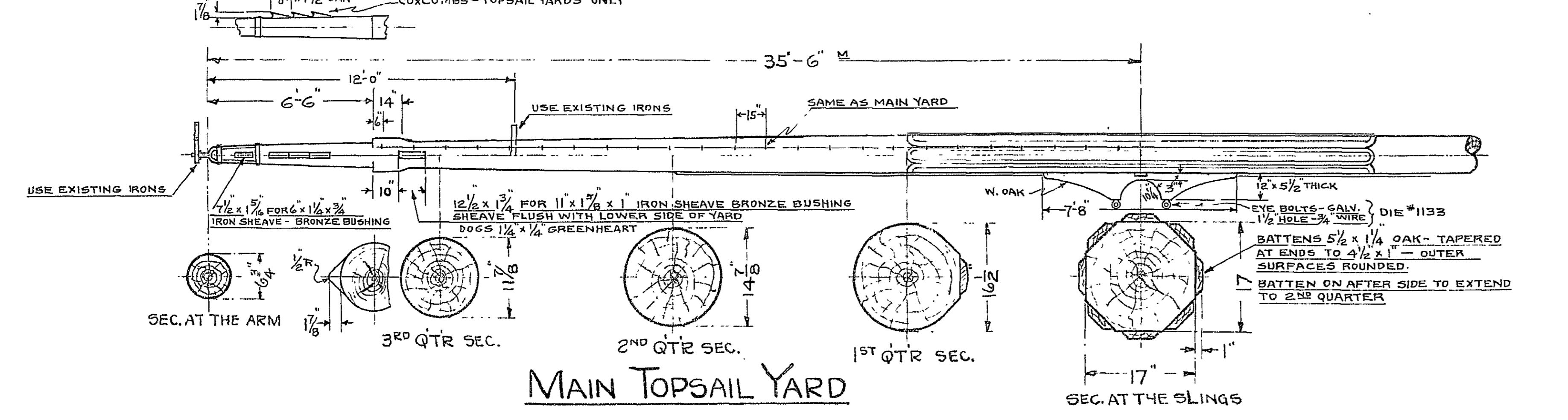

MAIN TOPSAIL YARD

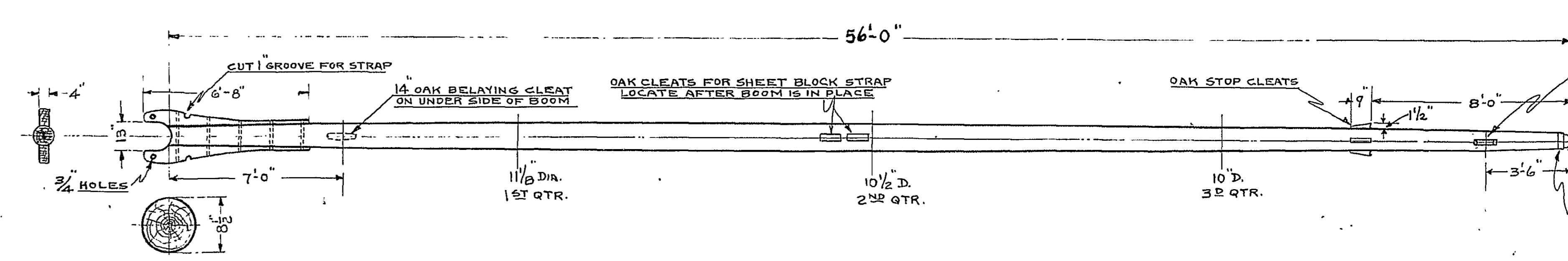

SPANKER BOOM

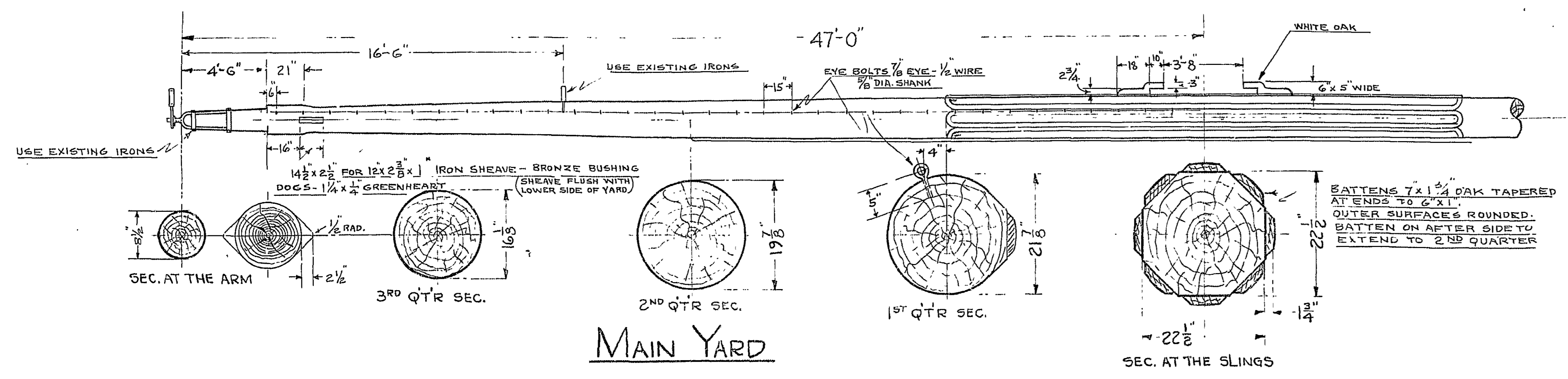

MAIN YARD

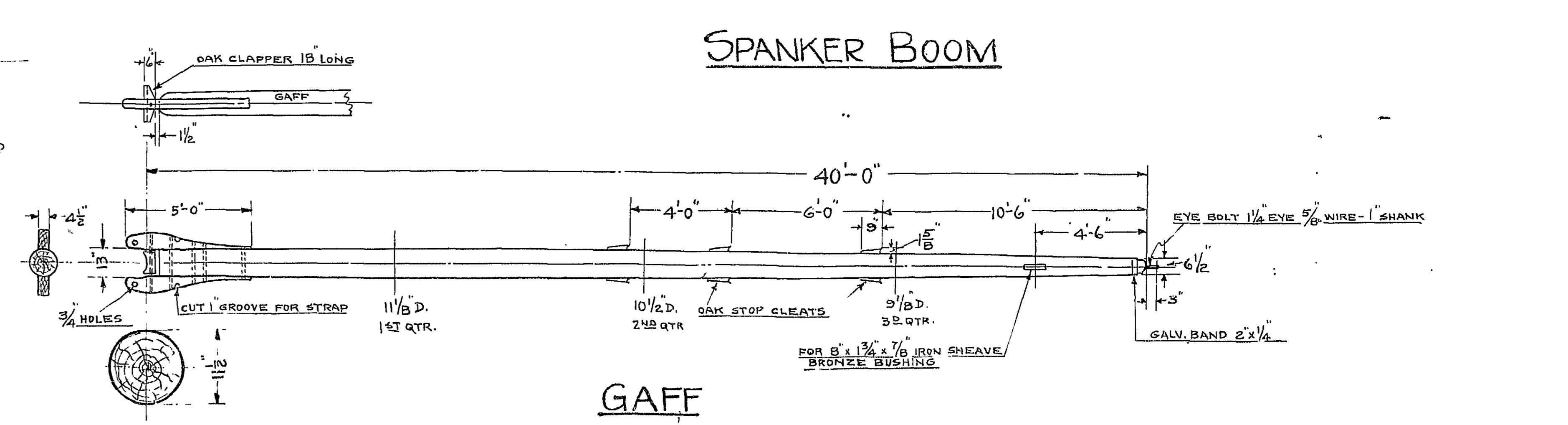

GAFF

IN CHARGE OF WORK: JOHN A. LOBB, LIEUT. (C.C.) U.S.N.
 DRAWN BY: M. CUNHA
 TRACED BY: M. CUNHA
 CHECKED BY: C. S. ADAMS

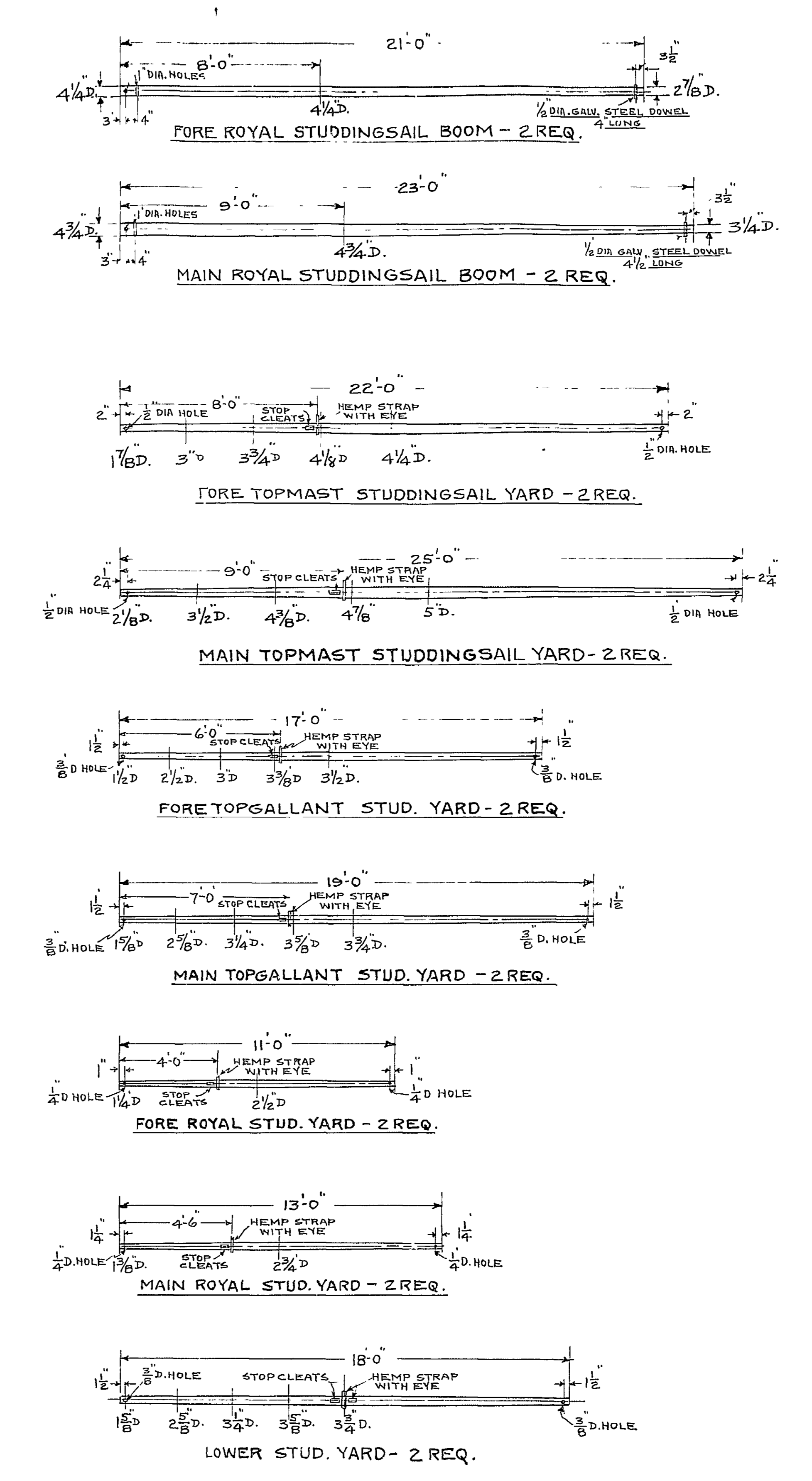
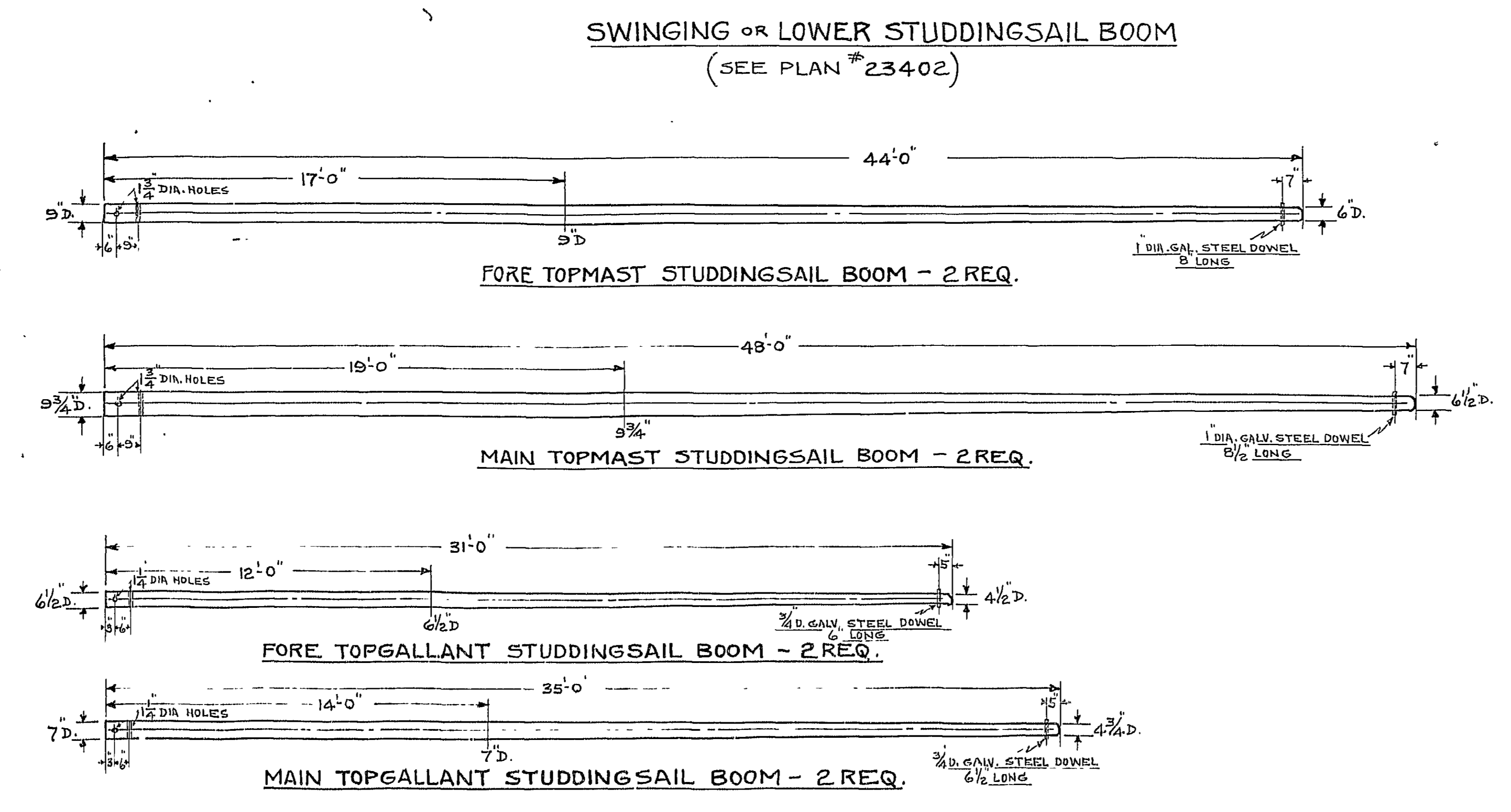
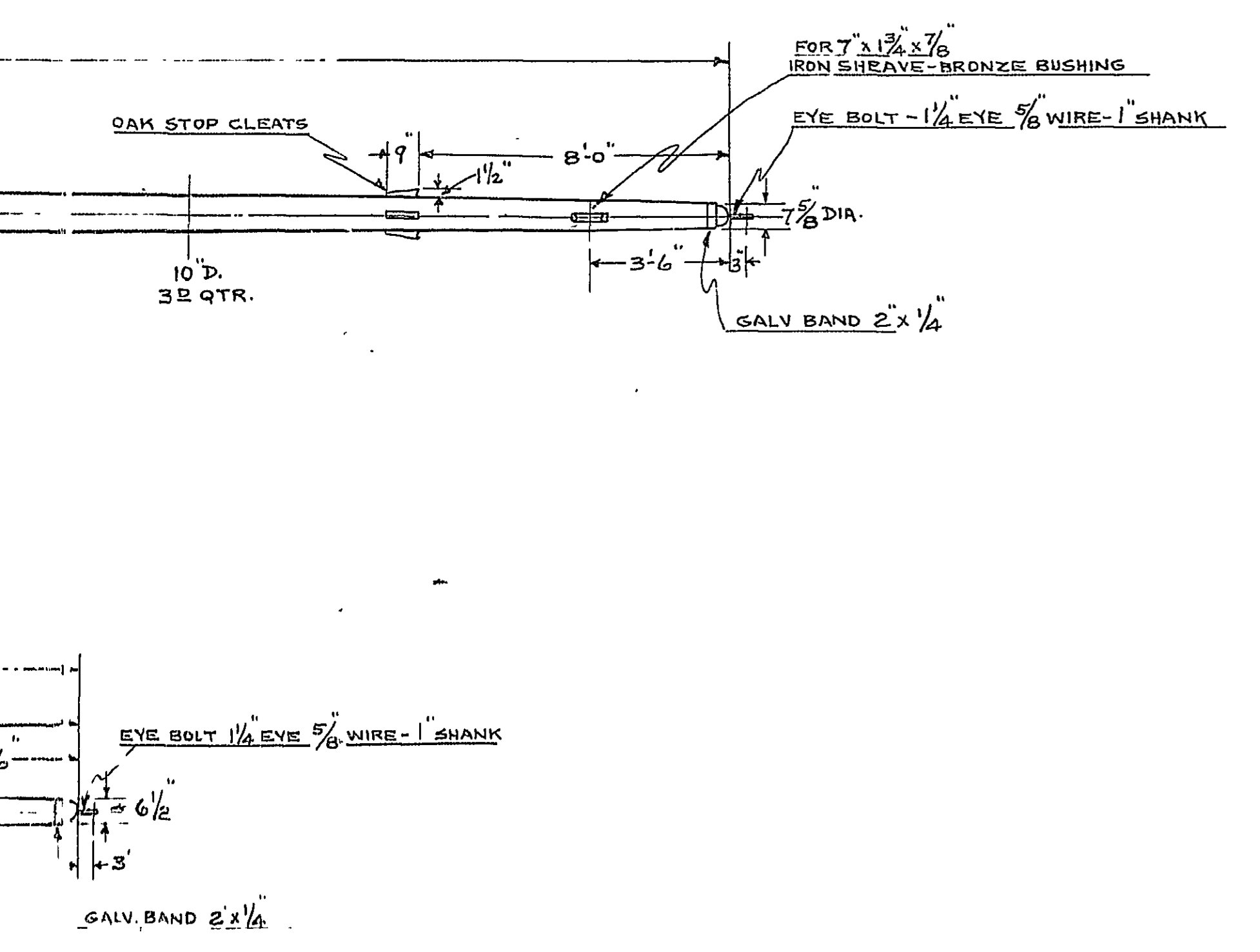
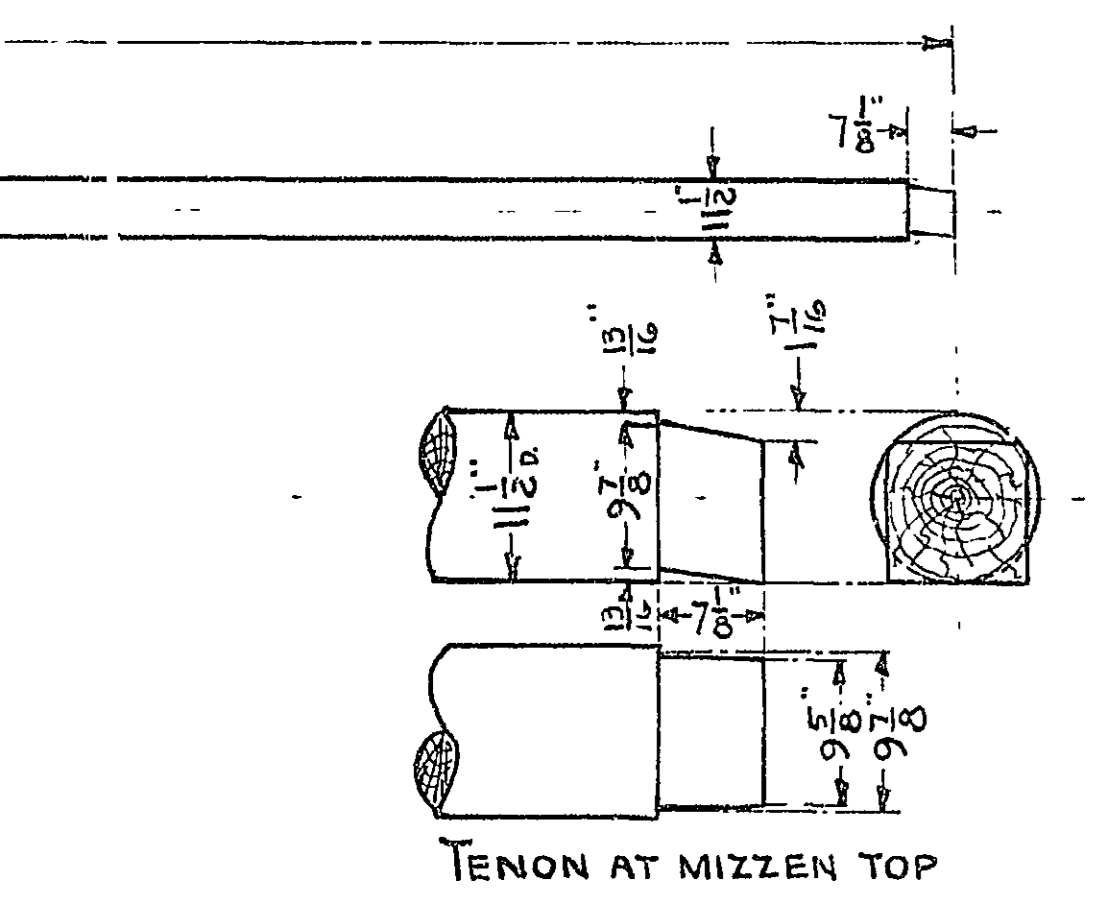
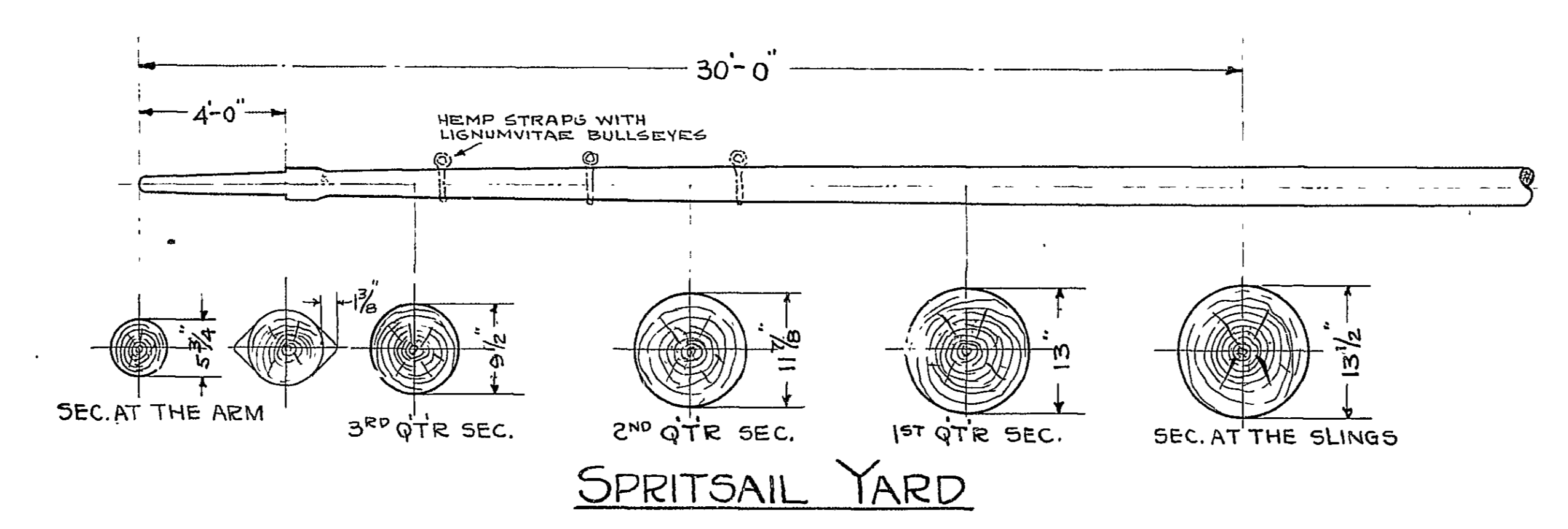
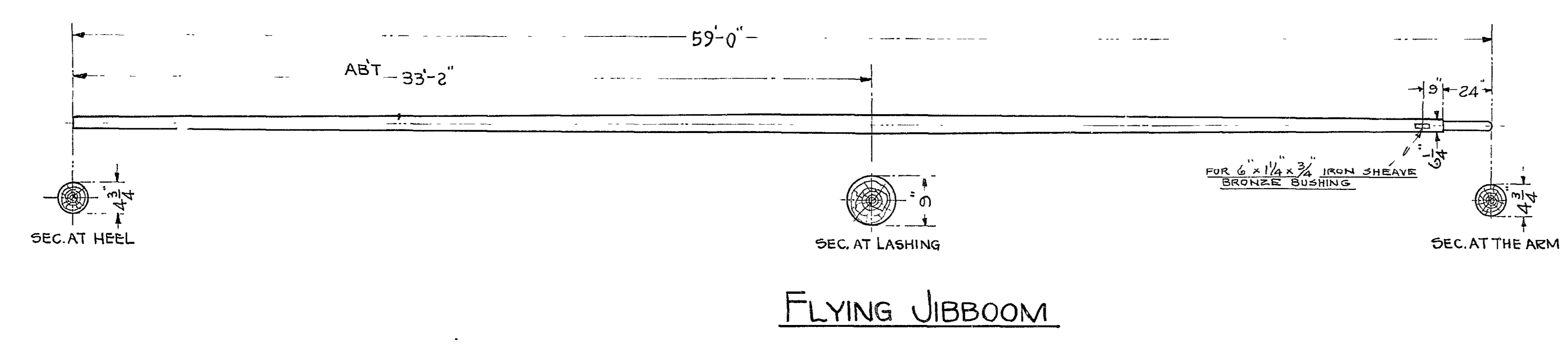
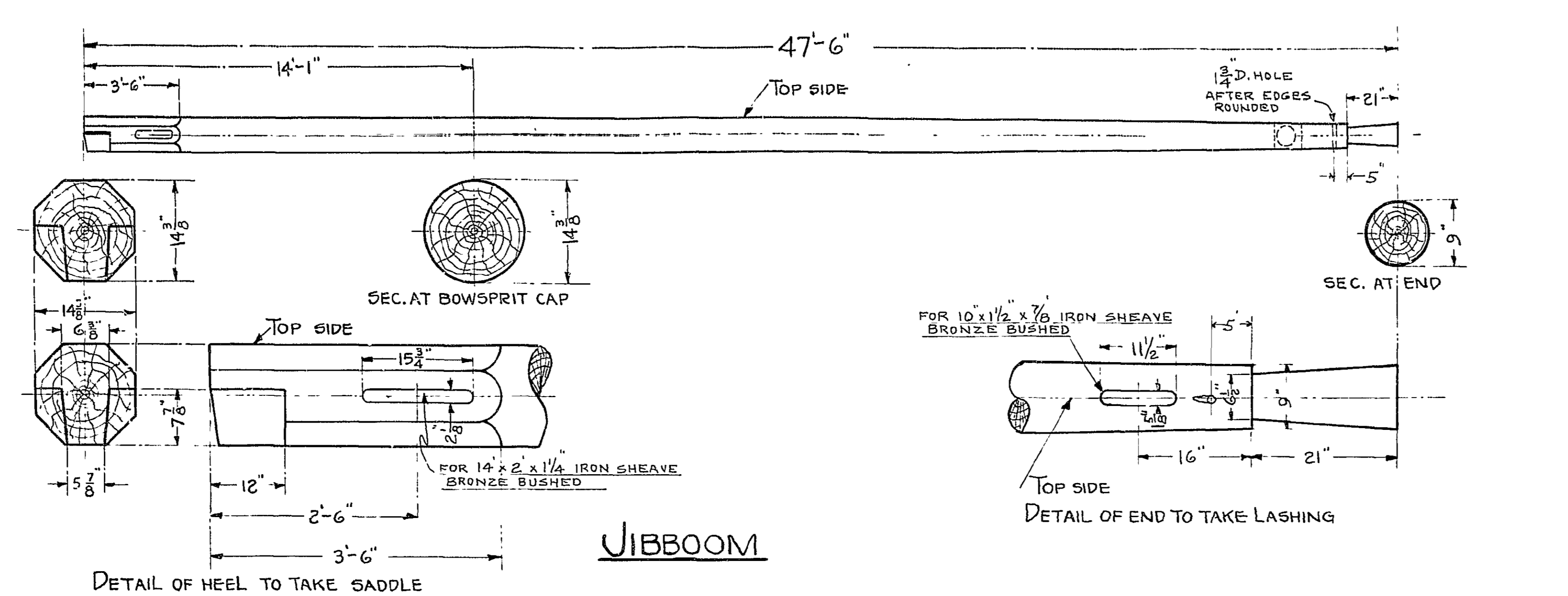
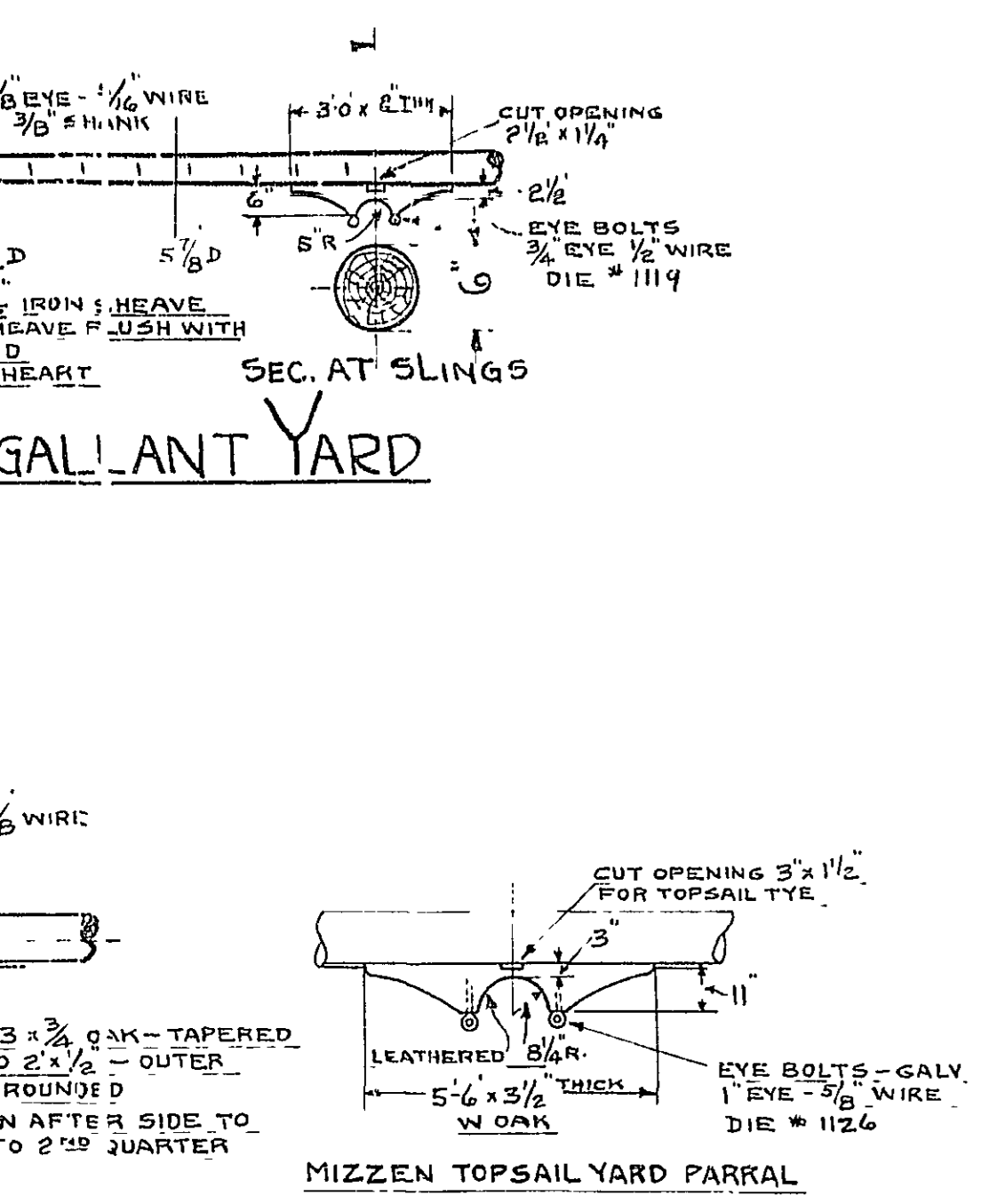

RESTORATION 1927-1931

U.S. FRIGATE CONSTITUTION

SPANKER MAST, YARDS, GAFF, BOOMS AND FITTINGS

NAVY YARD, BOSTON
 SCALE: 1/4" = 3/4" = 1 FT.

JULY 1929

R. W. Bush
 APPROVED FOR MANAGER

No. 30651